

PARAMOTORE SPECIFICO - SPECIFIC ENGINE GUARD - PARE-CARTER SPECIFIQUE  
 SPEZIFISCHER STURZB GEL - DEFENSA DE MOTOR ESPECIFICA

# TRIUMPH TIGER 1050 2007

ISTRUZIONI DI MONTAGGIO - MOUNTING- INSTRUCTIONS  
 INSTRUCTIONS DE MONTAGE - BAUANLEITUNG - INSTRUCCIONES DE MONTAJE

SI RACCOMANDA DI FARE ESEGUIRE IL MONTAGGIO AD UN MECCANICO QUALIFICATO

WE RECOMMEND THAT THE MOUNTING IS CARRIED OUT BY A QUALIFIED MOTORCYCLE MECHANIC

IL EST RECOMMANDE DE FAIRE EXECUTER LE MONTAGE PAR UN MECANICIEN QUALIFIE WIR EMPFEHLEN, DAS DIE MONTAGE VON EINEM FACHMECHANIKER DURCHGEF HRT WIRD

LES RECOMENDAMOS QUE EL MONTAJE DE LA DEFENSA SE REALICE POR UN MEC NICO CALIFICADO

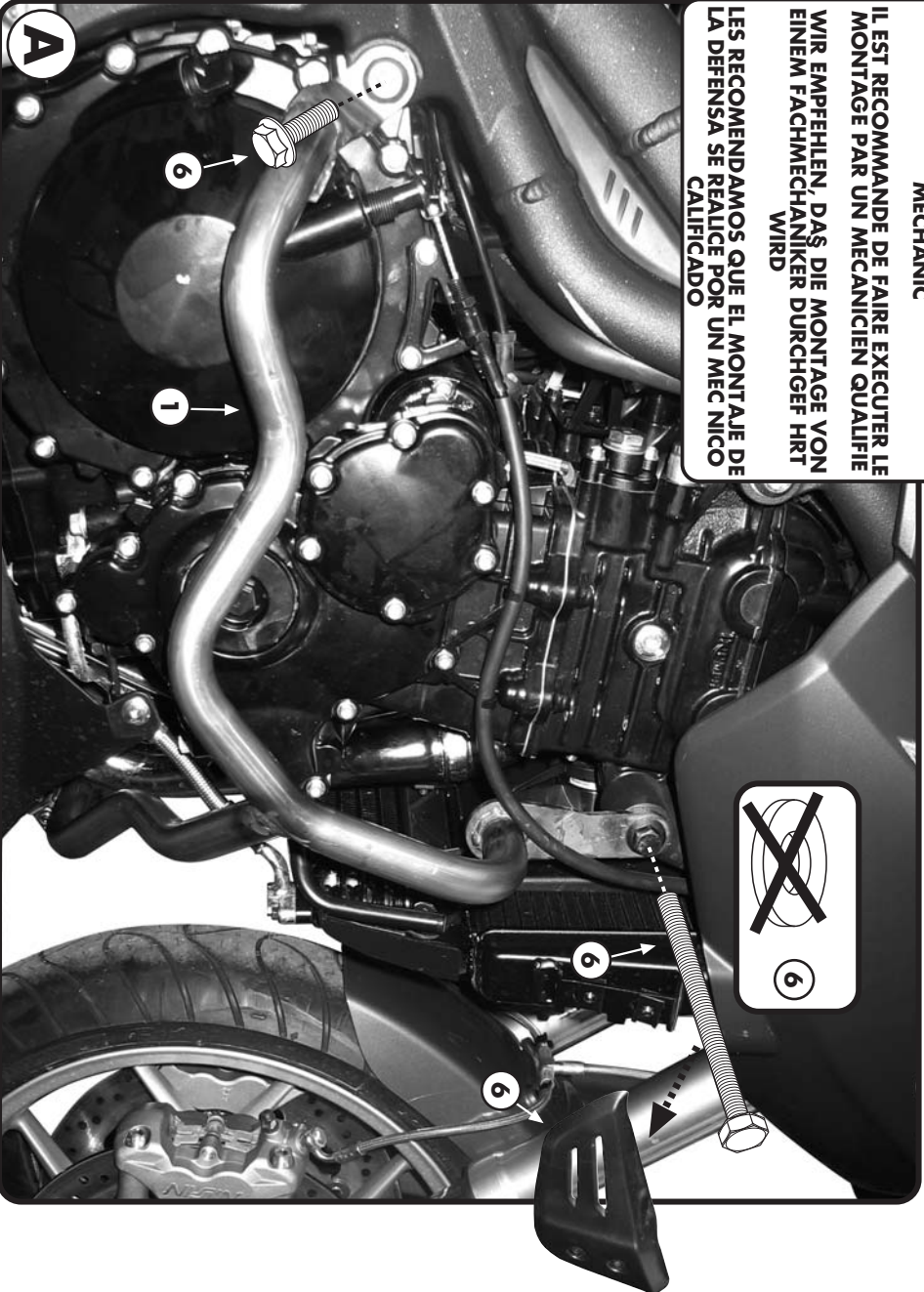

**1**

PARAMOTORE ENGINE GUARD PARE-CARTER DEFENSA DE MOTOR

Q.TY n.2(dx+sx)

**2**

DISTANZIALE fit 4x20mm  
 PASTOR 18,5mm, 0009  
 DISTANZSTÜCK  
 DISTANCIADOR

Q.TY n.1

**3**

VITE TCEI M8x3,5mm  
 SCREW M8x3,5mm  
 VIS M8x3,5mm  
 SCHRAUBE M8x3,5mm  
 TORNILLO M8x3,5mm

Q.TY n.1

**4**

RONDELLA 18mm  
 WASHER Ø18mm  
 RONDELLE Ø18mm  
 SCHEIBE Ø18mm  
 ARANDELA Ø18mm

Q.TY n.1

**5**

NIPPLES 347TN

Q.TY n.1

**6**

COMPONENTI ORIGINALI  
 ORIGINAL PARTS  
 PARTES ORIGINALES  
 ORIGINAL BAUTEILE  
 COMPONENTES ORIGINALES

Q.TY n.-

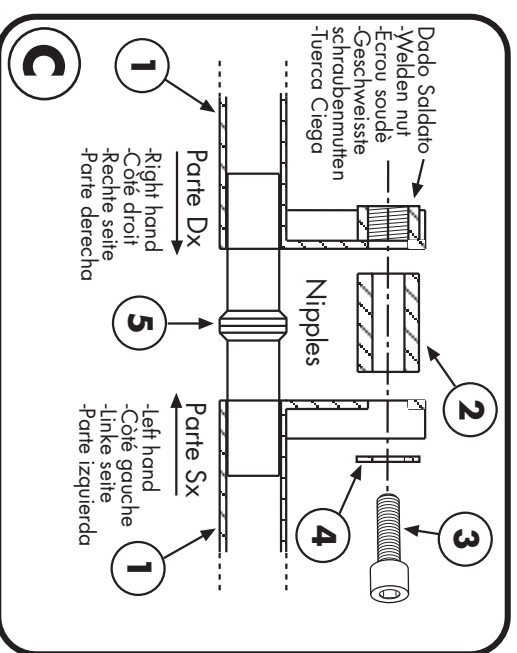
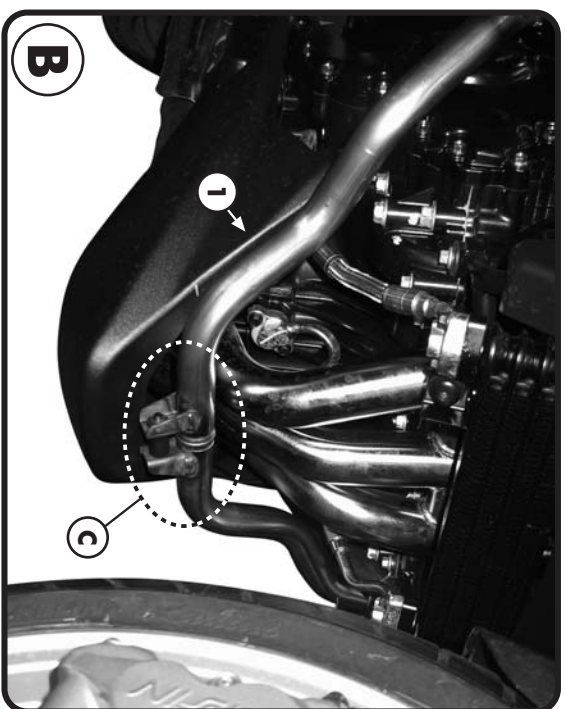

PARAMOTORE SPECIFICO - SPECIFIC ENGINE GUARD - PARE-CARTER SPECIFIQUE  
 SPECIFISCHER STURZB GEL - DEFENSA DE MOTOR ESPECIFICA

# TRIUMPH TIGER 1050 2007

ISTRUZIONI DI MONTAGGIO - MOUNTING INSTRUCTIONS  
 INSTRUCTIONS DE MONTAGE - BAUANLEITUNG - INSTRUCCIONES DE MONTAJE

## I ISTRUZIONI DI MONTAGGIO

- RIMUOVERE IL CARTERINO IN PLASTICA ORIGINALE POSIZIONATO SOTTO AL FIANCHETTO DELLA MOTO.  
 - ESEGUIRE IL MONTAGGIO PROPOSTO IN FIGURA "A" RIUTILIZZANDO LE VITI ORIGINALI.  
 - POSIZIONARE IL NIPPLE E SEGUIRE IL MONTAGGIO PROPOSTO NELLO SCHEMA "C".  
 - ULTIMARE IL MONTAGGIO VERIFICANDO CHE TUTTE LE VITI SIANO SERRATE BENE (VITI M8=23Nm  
 VITI M10=50 Nm - VITI M12=87,3 Nm).

## GB MOUNTING INSTRUCTIONS

1. REMOVE THE ORIGINAL SMALL PLASTIC LOWER FAIRING COVER FROM THE SIDE OF THE MOTORCYCLE.
2. REMOVE THE ORIGINAL BIKE BOLTS (ITEMS 6) AS SHOWN IN PICTURE A, AND USE THESE BOLTS TO ATTACH THE ENGINE GUARD (ITEM 1 LEFT AND RIGHT)
3. CONNECT THE TWO BRACKETS BY USING BOLT AND WASHER (ITEMS 3&4) WITH THE SPACER (ITEM2) UNDERNEATH THE FRONT OF THE BIKE., AS SHOWN IN PICTURE B.
4. LEAVE THE ENGINE GUARDS SLIGHTLY LOOSE IN ORDER TO INSERT PART (ITEM 5) BETWEEN THE TWO BRACKETS (AS SHOWN IN PICTURE C). AFTER INSERTING ITEM 5 TIGHTEN BOLT (ITEM 3) CHECK ALL BOLTS ARE TIGHT AND THE ENGINE GUARDS ARE SECURE. ENJOY YOUR RIDE.

## F INSTRUCTIONS DE MONTAGE

1. ENLEVER LE PETIT CARTER PLASTIQUE D'ORIGINE POSITIONNEE SOUS LE COTE DE LA MOTO.
2. EXECUTER LE MONTAGE PROPOSE EN PHOTO A EN UTILISANT LES VIS D'ORIGINE.
3. POSITIONNER LES MANCHONS ET REALISER LE MONTAGE PROPOSE SUR LE SCHEMA C.
4. TERMINER LE MONTAGE EN CONTROLANT LE BON SERRAGE DE TOUTES LES VIS (VIS M8=23Nm - VIS M10=50Nm - VIS M12=87,3Nm).

## D BAUANLEITUNG

ENTFERNEN SIE DAS PLASTIKGEHÄUSE AN DER SEITE DES MOTORRADS.  
 FOLGEN SIE DER MONTAGE WIE IM BILD A GEZEIGT UND BENUTZEN SIE DIE ORIGINALSCHRAUBEN.  
 POSITIONIEREN SIE DIE NIPPLES UND FOLGEN SIE DER MONTAGE VON BILD C.  
 ZULETZT ÜBERPRÜFEN SIE, DASS ALLE SCHRAUBEN FESTGEZOGEN WURDEN (SCHRAUBEN M8=23NM - SCHRAUBEN M10=50 NM - SCHRAUBEN M12=87,3 NM).

## ES

## INSTRUCCIONES DE MONTAJE

1. QUITAR EL COLLIN DE PLASTICO ORIGINAL POSICIONADO EN LA PARTE LATERAL DELANTARA BAJA DE LA MOTOCICLETA
2. REALIZAR EL MONTAJE COMO SE INDICA EN LA FIGURA "A" UTILIZANDO LOS TORNILLOS ORIGINALES.
3. POSICIONAR EL NIPLE Y REALIZAR EL MONTAJE COMO SE MUESTRA EN LA IMAGEN "C".
4. TERMINAR EL MONTAJE COMPROBANDO QUE TODOS LOS TORNILLOS ESTEN BIEN APRETADOS (TORNILLOS M8=23Nm - TORNILLOS M10=50Nm - TORNILLOS M12=87,3 Nm).

